



Minimally Invasive Devices



Cardiac Cannulae

enableCV Company Description

enableCV empowers cardiac surgeons to perform life-saving procedures. Our innovative medical devices were designed to provide continuous blood flow during open-heart surgeries and enable trailblazing minimally invasive procedures. Building on our deep expertise developed through our heritage with Edwards Lifesciences, we're charting a new path as an independent company focused on next-generation cardiac surgery solutions. With collaborative input from a preeminent medical advisory board, enableCV is expanding our portfolio of products to continuously improve the experience of surgeons and their patients.

[enableCV, advancing the future of cardiac care.](#)

Table of Contents

Minimally Invasive Devices and Cardiac Cannulae

Minimally Invasive Devices

Retrograde cardioplegia.....	6
Aortic occlusion.....	7
Arterial cannulae.....	8
Femoral venous cannulae	10
Accessory devices	11

Cardiac Cannulae

Arterial cannulae.....	15
Venous cannulae	19
Femoral cannulae	32
Cardioplegia catheters	36

Index	43
-------------	----

Customer Service	45
------------------------	----

The background of the slide features a collection of medical devices, including laparoscopic instruments and long, thin tubes, arranged in a circular pattern. The devices are rendered in a semi-transparent, light blue color against a dark blue gradient background. The main title is enclosed in a white rounded rectangular frame.

Minimally Invasive Devices

*Disposable Products for
Minimal Incision Surgery*

Minimally Invasive Devices

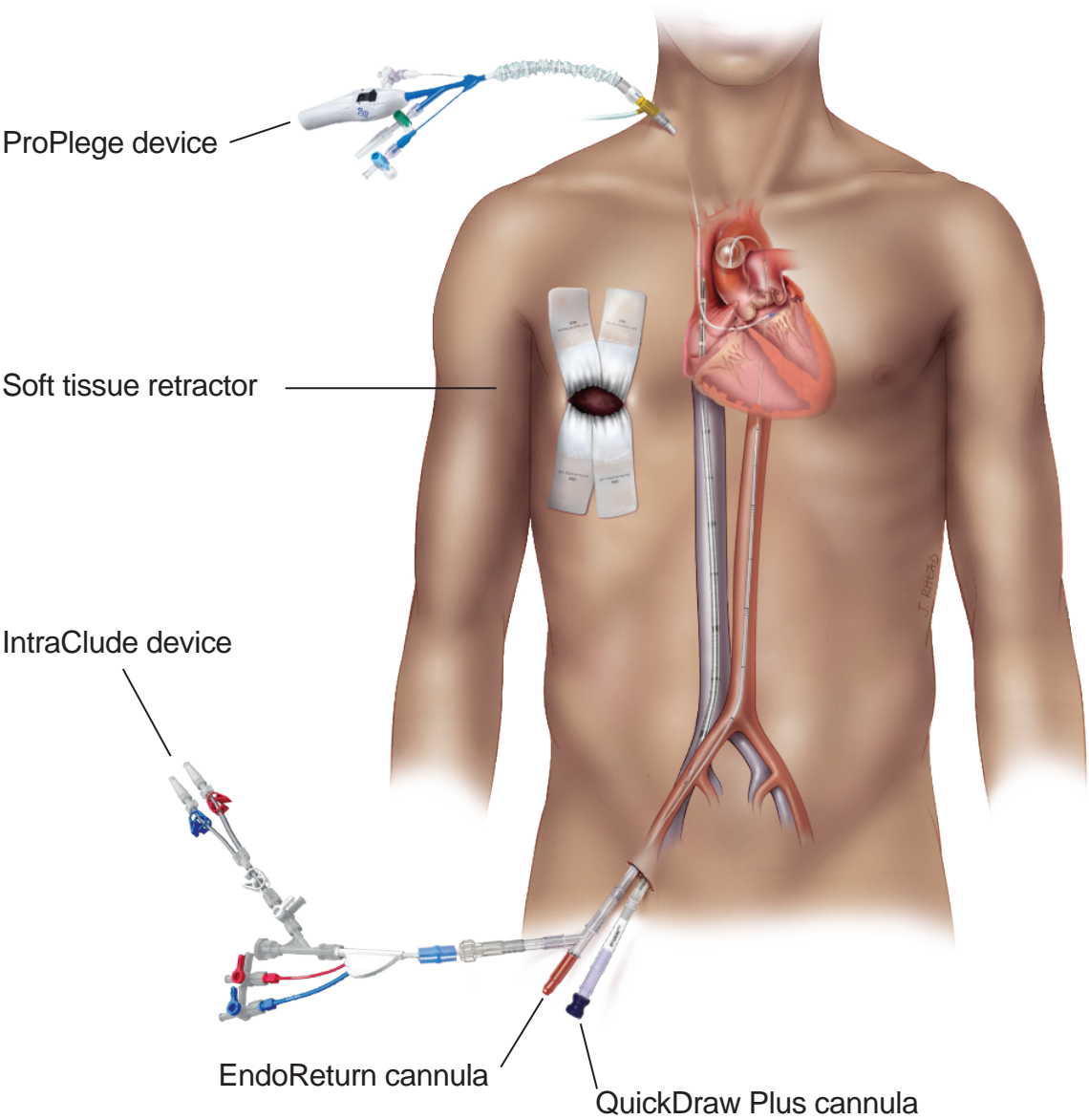

ProPlege Peripheral Retrograde Cardioplegia Device

The ProPlege device is indicated for occlusion of the coronary sinus, delivery of cardioplegia solution, and monitoring of coronary sinus pressure during cardiopulmonary bypass.

- 9 Fr (3.1 mm), 59 cm long, triple-lumen, articulating device
- Designed for occluding the coronary sinus for retrograde perfusion of the coronary circulation
- Balloon expands to occlude a range of coronary sinus diameters
- The large central lumen of the ProPlege device delivers cardioplegic solution to the coronary sinus
- The two remaining lumens serve as conduits for balloon inflation and coronary sinus pressure monitoring distal to the balloon
- The shaft features an articulation mechanism which changes the curvature of the distal end when the positioning dial is manipulated
- The ProPlege device is provided with a contamination guard, which connects to the introducer sheath

1 unit per case

23.2 inch (59 cm) effective length
32.3 inch (82 cm) overall length

PR9 9 Fr (3.1 mm) catheter

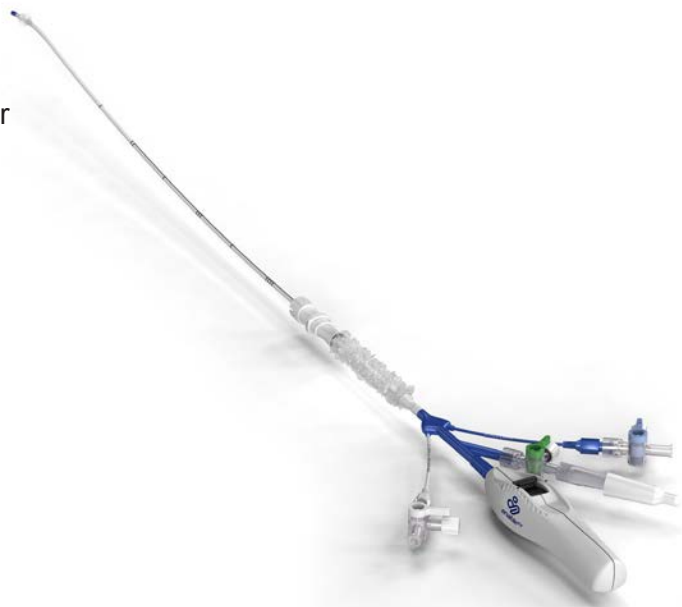

IntraClude Intra-Aortic Occlusion Device

The IntraClude intra-aortic occlusion device is indicated for use in patients undergoing cardiopulmonary bypass. The IntraClude intra-aortic occlusion device occludes and vents the ascending aorta when the balloon is inflated. The device's central lumen allows delivery of cardioplegia to arrest the heart. The pressure lumen allows monitoring of the aortic root pressure.

- 10.5 Fr (3.5 mm), triple-lumen, 100 cm long catheter
- Designed to occlude the ascending aorta in order to partition the aortic root from arterial circulation
- Balloon expands to occlude a range of aorta sizes from 20 to 40 mm
- Designed to be used in the femoral approach with the EndoReturn (ER21B or ER23B) arterial cannula or the introducer sheath (IS19A)
- The shaft is provided with an extended strain relief designed to prevent kinking

1 unit per case

39.4 inch (100 cm) overall length

ICF100 0.038 inch (200 cm) guidewire
Y-connector
Red and blue pressure lines

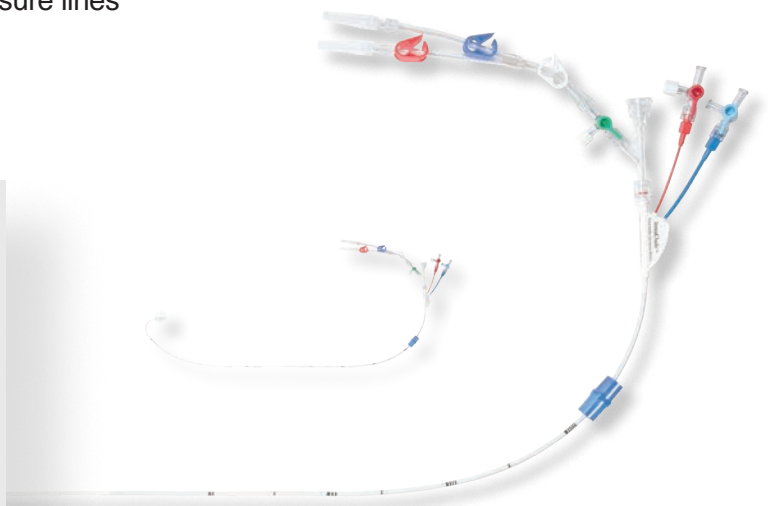
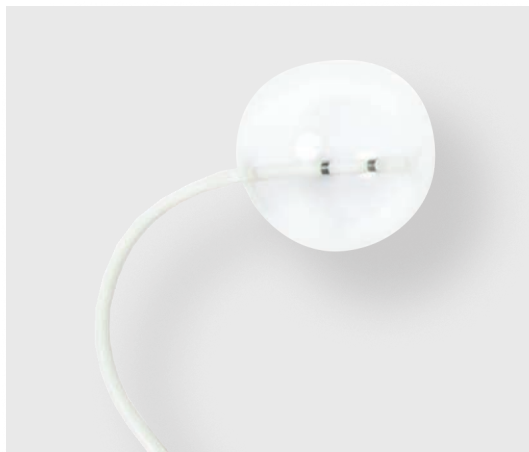

EndoReturn Arterial Cannula

The EndoReturn arterial cannula and 19 Fr (6.3 mm) arterial cannula are indicated for patients undergoing cardiopulmonary bypass. They are intended to deliver oxygenated blood for cardiopulmonary bypass during surgery. The EndoReturn arterial cannula with hemostasis valve also allows the hemostatic introduction and removal of vascular catheters such as the IntraClude intra-aortic occlusion device.

- Kits include a wire-reinforced cannula with hemostasis valve, an introducer and a guidewire
- The cannulae have a wire-reinforced section to provide kink resistance and flexibility
- Tapered tips to aid in insertion and advancement into the femoral artery
- Hemostasis valve designed to allow passage of catheters, such as the IntraClude intra-aortic occlusion device
- The introducers accept a .038 inch (0.97 mm) guidewire and are marked to simplify assembly and indicate alignment
- A lubricious coating is applied to the surface of the cannula body, designed to ease insertion and retraction of catheters and introducers

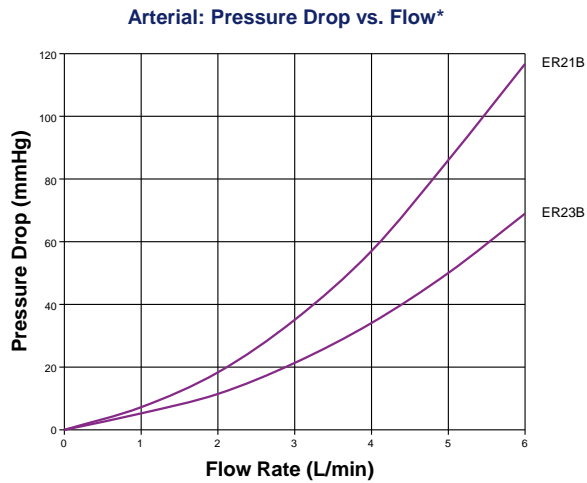

* Mean value derived from in vitro testing performed with water at 21°C. The actual pressure gradients encountered in a clinical situation may vary from those shown, depending on perfusion techniques.

1 unit per case

3.7 inch (9.4 cm) effective length

ER21B	21 Fr (7.0 mm) 0.038 inch (100 cm) guidewire Introducer Connector hub
ER23B	23 Fr (7.6 mm) 0.038 inch (100 cm) guidewire Introducer Connector hub



3.7 inch (9.4 cm) effective length

IS19A	19 Fr (6.3 mm) 0.038 inch (100 cm) guidewire Introducer
-------	---



Arterial Cannulae

OptiSite Arterial Cannula

The OptiSite arterial perfusion cannulae are indicated for arterial perfusion in the extracorporeal circuit for < 6 hours. Cannulation site selection is left to the discretion of the surgeon and may include the femoral artery or the aortic arch.

- Smoothly rounded tips to facilitate atraumatic insertion
- The proximal ends of the cannulae are designed to accept 3/8 inch (9.5 mm) tubing
- Lock introducer is designed for use with 0.038 inch (0.96 mm) guidewires
- Removable vented luer cap designed to allow cannula venting when guidewire is not in use

1 unit per case

Blunt tip introducer

15 cm effective length
20.8 cm overall length

Vented 3/8 inch connector

OPTI16	16 Fr (5.3 mm)
OPTI18	18 Fr (6.0 mm)
OPTI20	20 Fr (6.7 mm)
OPTI22	22 Fr (7.3 mm)

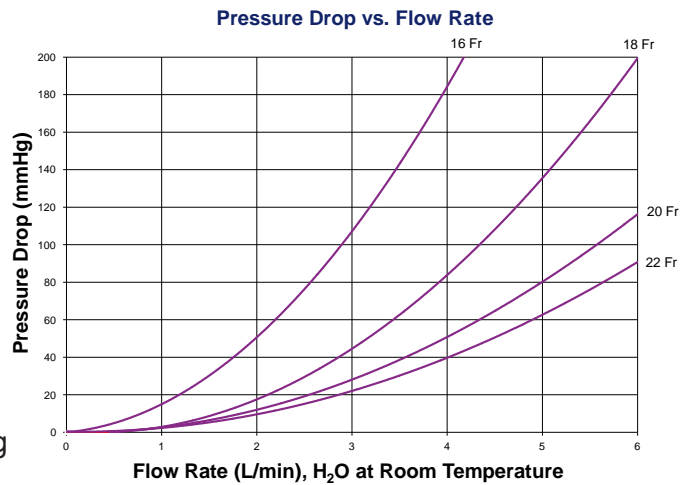

Femoral Venous Cannulae

QuickDraw Plus Femoral Venous Cannula

The QuickDraw Plus femoral venous cannula is indicated for draining non-oxygenated blood from the vena cava or right atrium during cardiopulmonary bypass.

- Engineered to facilitate simplified percutaneous insertion
- With proprietary spiraled drainage holes, the cannula is designed for reliable performance with less risk of side occlusion
- Thin-walled technology optimizes flow while maintaining crush and kink resistance

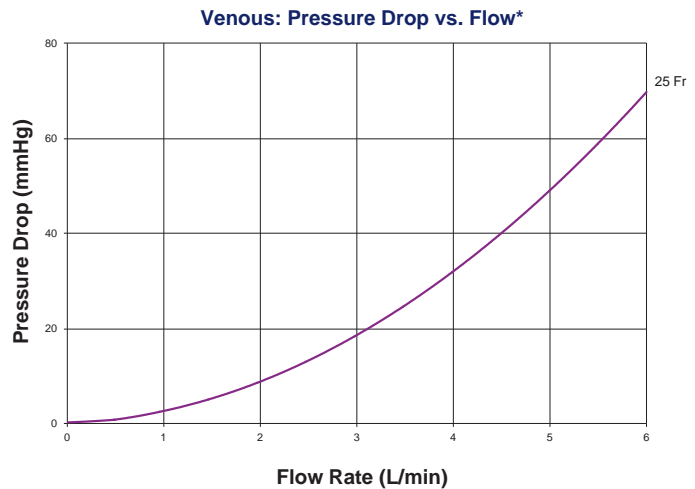

* Mean value derived from In-Vitro testing performed with water at ambient temperature. Due to increased viscosity of blood, actual pressure gradients encountered in a clinical situation may vary from these shown.

1 unit per case

65 cm overall length

QDP25 25 Fr (8.3 mm)

Package contents:

- 25 Fr (8.3 mm) cannula
- Introducer with alignment marker
- 3/8 in (9.5 cm) barbed connector hub



Note: Insertion components are not included.
PIKV5 Percutaneous Insertion Kit is recommended.

Soft Tissue Retractor

The soft tissue retractor is used to allow visualization of intrathoracic structures and provide entry for the instruments into the thoracic cavity during specific cardiac surgical procedures. The soft tissue retractor is designed to be inserted into an intercostal incision and retract tissue to form a port.

- Available in three sizes
- Fabric tabs designed to retract tissue from the incision
- Soft, polyester fabric conforms to intercostal incision
- Metallic ring compresses for insertion into thorax

Model	Description	Ring diameter	Tab length	Tab width
TRS	Soft tissue retractor, small	2.2 inch (6.0 cm)	6.0 inch (15.2 cm)	1.5 inch (3.8 cm)
TRM	Soft tissue retractor, medium	3.0 inch (7.5 cm)	6.0 inch (15.2 cm)	2.0 inch (5.1 cm)
TRL	Soft tissue retractor, large	3.5 inch (9.0 cm)	6.0 inch (15.2 cm)	2.5 inch (6.4 cm)



Knot Pusher

- Knot pusher facilitates extracorporeal knot tying of valve sutures

KP1	12.9 inch (33 cm) length	
-----	--------------------------	--

Janke-Barron Heart Support

The Janke-Barron heart support is designed for effective and convenient support of the heart during coronary artery surgery, specifically bypass operations on the circumflex artery system.

- Configuration: Openwork pattern, square openings, approximately 1.5 cm
- Width: Approximately 20 cm
- Length: Approximately 20 cm
- Tapes: 6 mm wide, folded from 2.5 cm strips
- Thread: Polyester, approximately 5 stitches per cm

Model	Description	Size
4800	Janke-Baron heart support	Individual supports are supplied 6 to a box

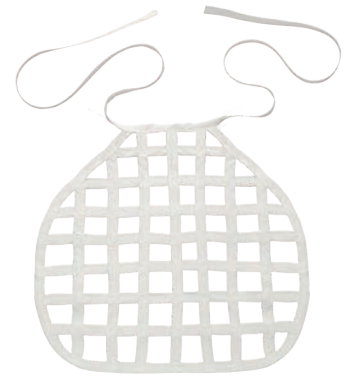

Percutaneous Insertion Kit

The percutaneous insertion kit is designed to facilitate percutaneous insertion of a femoral cannula. The kit includes the following components:

- Number 11 scalpel
- 18 ga. insertion needle
- 5 mL syringe
- Dilator sizes: 8 Fr / 12 Fr / 16 Fr / 20 Fr / 24 Fr
- 0.038 inch guidewire

5 units per case

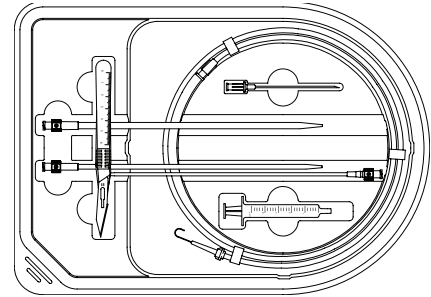

Venous insertion kit

PIKV5

210 cm guidewire

Cardiac Cannulae

- *Arterial Cannulae*
- *Venous Cannulae*
- *Femoral Cannulae*
- *Cardioplegia Catheters*

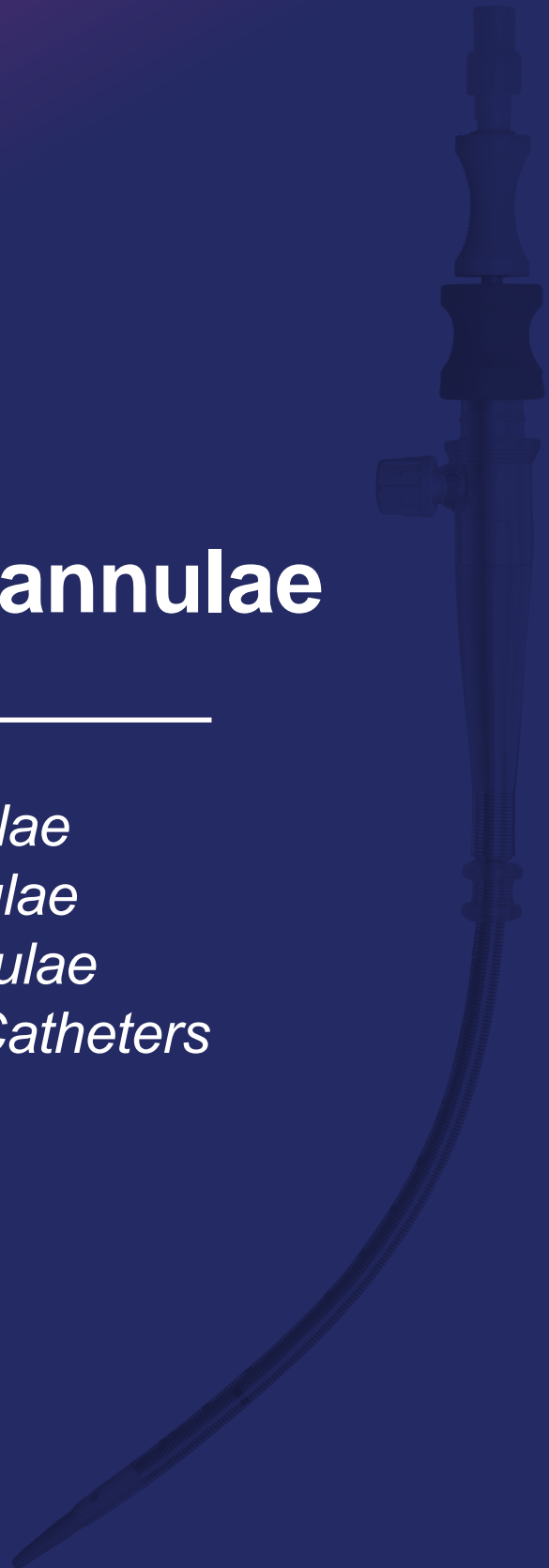

Arterial Cannulae

Aortic perfusion cannulae may be used in pediatric or adult populations based on the flow rate requirements and individual patient anatomy. Please consult labeling to determine pressure drop related to flow rates.

OptiSite Arterial Cannula

The OptiSite arterial perfusion cannulae are indicated for arterial perfusion in the extracorporeal circuit for < 6 hours. Cannulation site selection is left to the discretion of the surgeon and may include the femoral artery or the aortic arch.

- Smoothly rounded tips to facilitate atraumatic insertion
- The proximal ends of the cannulae are designed to accept 3/8 inch (9.5 mm) tubing
- Lock introducer is designed for use with 0.038 inch (0.96 mm) guidewires
- Removable vented luer cap designed to allow cannula venting when guidewire is not in use

1 unit per case

Blunt tip introducer

15 cm effective length
20.8 cm overall length

Vented 3/8 inch connector

OPTI16	16 Fr (5.3 mm)
OPTI18	18 Fr (6.0 mm)
OPTI20	20 Fr (6.7 mm)
OPTI22	22 Fr (7.3 mm)

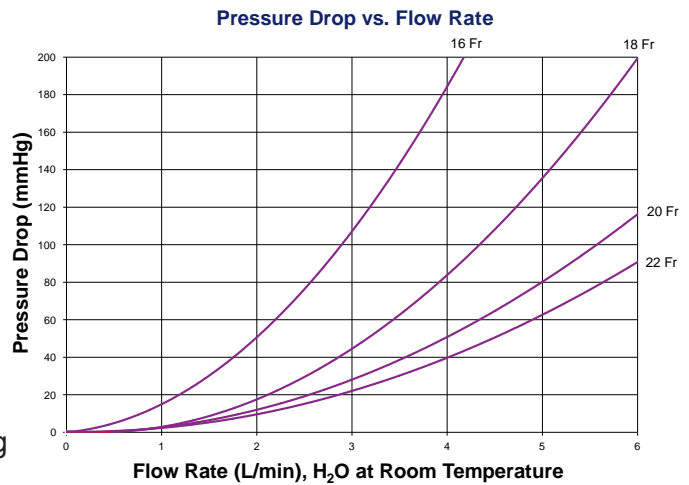

Arterial Cannulae

EZ Glide Aortic Perfusion Cannula

The EZ Glide aortic perfusion cannula is intended to create a dispersive flow.

- Tip design disperses return flow in a conical spray pattern
- Unique auto-dilating tip

10 units per case

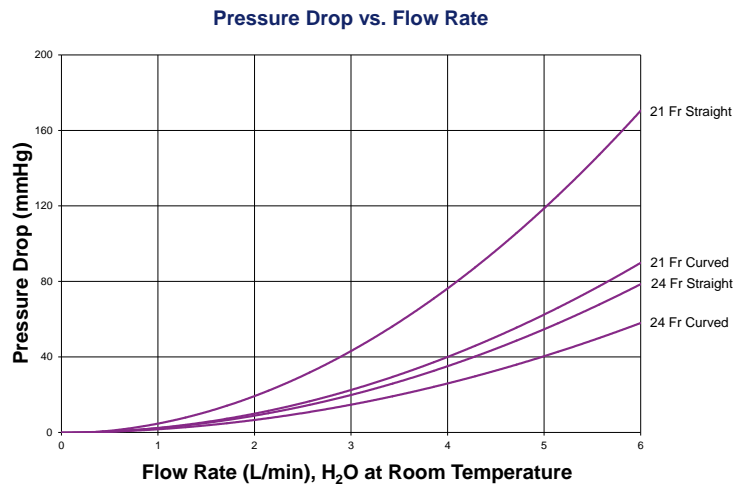

Straight cannula

14 inch (35 cm) overall length

3/8 inch vented connector

EZS21TA 21 Fr (7.0 mm)
EZS24TA 24 Fr (8.0 mm)



3/8 inch non-vented connector

EZS21A 21 Fr (7.0 mm)
EZS24A 24 Fr (8.0 mm)



EZ Glide Aortic Perfusion Cannula *(continued)*

Curved cannula with suture bump

14.8 inch (37.6 cm) overall length

3/8 inch vented connector

EZC21TA 21 Fr (7.0 mm)

EZC24TA 24 Fr (8.0 mm)



3/8 inch non-vented connector

EZC21A 21 Fr (7.0 mm)

EZC24A 24 Fr (8.0 mm)



Curved cannula with suture flange

14.8 inch (37.6 cm) overall length

3/8 inch vented connector

EZF21TA 21 Fr (7.0 mm)

EZF24TA 24 Fr (8.0 mm)



3/8 inch non-vented connector

EZF21A 21 Fr (7.0 mm)

EZF24A 24 Fr (8.0 mm)



Venous Cannulae

Venous cannulae may be used in pediatric populations or adult populations based on flow rate requirements and patient anatomy. Please see labeling for maximum flow rate information.

QuickDraw Plus Femoral Venous Cannula

The QuickDraw Plus femoral venous cannula is indicated for draining non-oxygenated blood from the vena cava or right atrium during cardiopulmonary bypass.

- Engineered to facilitate simplified percutaneous insertion
- With proprietary spiraled drainage holes, the cannula is designed for reliable performance with less risk of side occlusion
- Thin-walled technology optimizes flow while maintaining crush and kink resistance

1 unit per case

65 cm overall length

QDP25 25 Fr (8.3 mm)

Package contents:

- 25 Fr (8.3 mm) cannula
- Introducer with alignment marker
- 3/8 in (9.5 cm) barbed connector hub

Note: Insertion components are not included.
PIKV5 Percutaneous Insertion Kit is recommended.

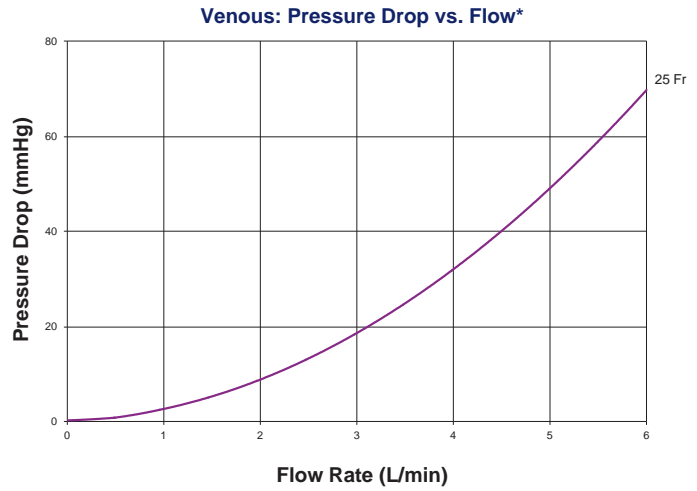

* Mean value derived from In-Vitro testing performed with water at ambient temperature. Due to increased viscosity of blood, actual pressure gradients encountered in a clinical situation may vary from these shown.



Triple Stage Venous Cannula

- Thin-Flex triple stage venous cannula offers 34% reduction in wall thickness compared to traditional technology*
- Open lighthouse tip for high flow rates
- Compatible with vacuum assist venous drainage systems
- Optional Trim-Flex low profile venous cannula offers a flattened design*

10 units per case

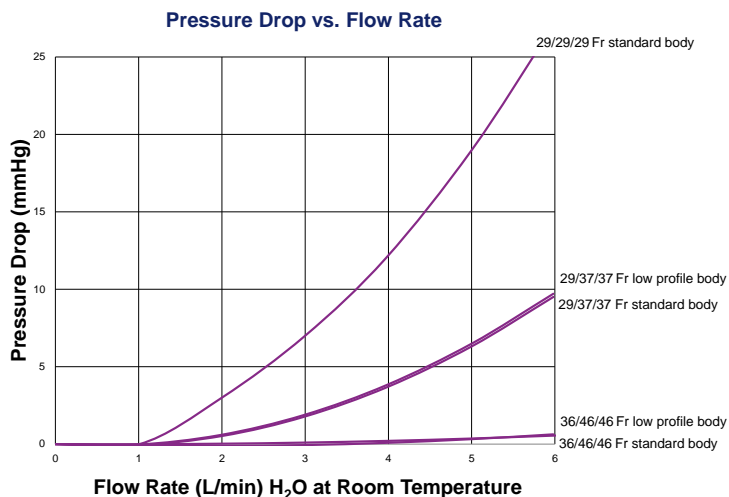

Trim-Flex low profile triple stage venous cannula

14.5 inch (37 cm) overall length

1/2 inch non-vented connector

TRF2937O2A 29/37/37 Fr
(9.6/12.3/12.3 mm)



1/2 inch acceptance

TRF2937O2 29/37/37 Fr
(9.6/12.3/12.3 mm)



16 inch (40 cm) overall length

1/2 inch non-vented connector

TRF3646O2A 36/46/46 Fr
(12.0/15.3/15.3 mm)



1/2 inch acceptance

TRF3646O2 36/46/46 Fr
(12.0/15.3/15.3 mm)



* As compared to standard venous cannulae, data on file

Triple Stage Venous Cannula *(continued)*

Thin-Flex triple stage venous cannula

14.5 inch (37 cm) overall length

1/2 inch non-vented connector

TF293702A 29/37/37 Fr
(9.6/12.3/12.3 mm)



1/2 inch acceptance

TF293702 29/37/37 Fr
(9.6/12.3/12.3 mm)



16 inch (40 cm) overall length

1/2 inch non-vented connector

TF292902A 29/29/29 Fr
(9.6/9.6/9.6 mm)



3/8 inch acceptance

TF292902 29/29/29 Fr
(9.6/9.6/9.6 mm)



1/2 inch acceptance

TF364602 36/46/46 Fr
(12.0/15.3/15.3 mm)



Venous Cannulae

Dual Stage Venous Cannula

- Features patented dual stage drainage baskets designed to provide increased resistance to collapse
- Multiple port tip designed to increase drainage
- Wire-reinforcement helps reduce kinking and twisting
- Optional Thin-Flex dual stage venous cannula with proprietary thin-wall technology designed to maximize flow rates and available space

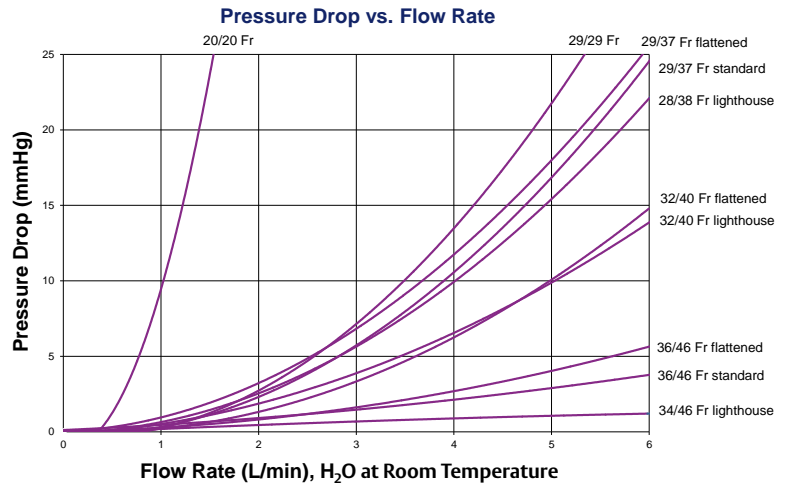

10 units per case

Trim-Flex low profile dual stage cannula

14.5 inch (37 cm) overall length

1/2 inch non-vented connector

TRF2937OA 29/37 Fr (9.6/12.3 mm)



1/2 inch acceptance

TRF2937O 29/37 Fr (9.6/12.3 mm)

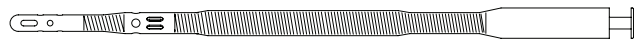

16 inch (40 cm) overall length

1/2 inch non-vented connector

TRF3646OA 36/46 Fr (12.0/15.3 mm)



1/2 inch acceptance

TRF3646O 36/46 Fr (12.0/15.3 mm)



Dual Stage Venous Cannula (continued)

Thin-Flex dual stage venous cannula

14.5 inch (37 cm) overall length

1/2 inch non-vented connector
 TF2937OA 29/37 Fr (9.6/12.3 mm)



1/2 inch acceptance
 TF2937O 29/37 Fr (9.6/12.3 mm)



16 inch (40 cm) overall length

3/8 inch acceptance
 TF292901 29/29 Fr (9.6/9.6 mm)



1/2 inch non-vented connector
 TF3646OA 36/46 Fr (12.0/15.3 mm)
 TF3343OA 33/43 Fr (11.0/14.3 mm)



1/2 inch acceptance
 TF3646O 36/46 Fr (12.0/15.3 mm)
 TF3343O 33/43 Fr (11.0/14.3 mm)



Thin-Flex dual stage venous cannula angled

14 inch (35 cm) overall length

1/2 inch acceptance
 TF2937O120 29/37 Fr (9.6/12.3 mm)

15 inch (37.5 cm) overall length

1/2 inch acceptance
 TF3646O120 36/46 Fr (12.0/15.3 mm)

1/2 inch connector
 TF3646OA120 36/46 Fr (12.0/15.3 mm)

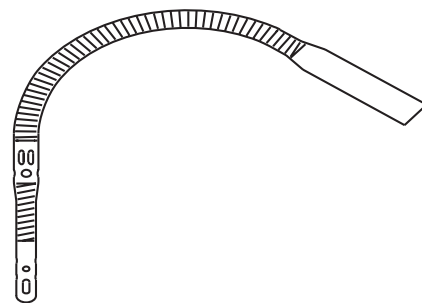

Dual Stage Venous Cannula (continued)

Open lighthouse tip

16 inch (40 cm) overall length

1/2 inch non-vented connector

TR3240OA 32/40 Fr (10.6/13.3 mm)



1/2 inch acceptance

TR3240O 32/40 Fr (10.6/13.3 mm)



Lighthouse tip

16 inch (40 cm) overall length

1/2 inch acceptance

TR2838L 28/38 Fr (9.3/12.6 mm)

TR3240L 32/40 Fr (10.6/13.3 mm)

TR3446L 34/46 Fr (11.3/15.3 mm)



Bullet tip

16 inch (40 cm) overall length

1/2 inch acceptance

TR3651B 36/51 Fr (12.0/17.0mm)



Venous Cannulae

Single Stage Venous Cannula

- One piece wire reinforced cannula
- Proprietary thin-wall design to maximize venous drainage
- Multiple port tip designed to increase drainage
- Thin-Flex venous cannula with proprietary thin-wall technology designed to maximize flow rates

10 units per case

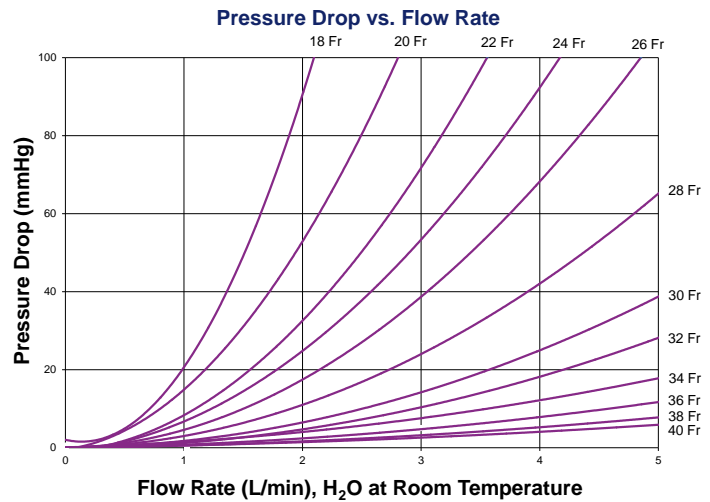

Thin-Flex straight open lighthouse tip

14 inch (35 cm) overall length

1/4 inch or 3/8 inch acceptance

TF018L	18 Fr (6.0 mm)
TF020L	20 Fr (6.7 mm)
TF022L	22 Fr (7.3 mm)
TF024L	24 Fr (8.0 mm)



3/8 inch acceptance

TF026L	26 Fr (8.7 mm)
TF028L	28 Fr (9.3 mm)



16 inch (40 cm) overall length

3/8 inch acceptance

TF030L	30 Fr (10.0 mm)
TF032L	32 Fr (10.7 mm)
TF034L	34 Fr (11.3 mm)
TF036L	36 Fr (12.0 mm)
TF038L	38 Fr (12.6 mm)
TF040L	40 Fr (13.3 mm)



Single Stage Venous Cannula (continued)

Thin-Flex right angled open lighthouse tip

14 inch (35 cm) overall length

1/4 inch or 3/8 inch acceptance
TF024L90 24 Fr (8.0 mm)

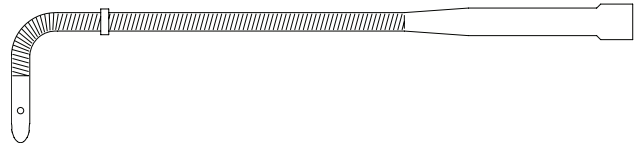

3/8 inch acceptance
TF026L90 26 Fr (8.7 mm)
TF028L90 28 Fr (9.3 mm)



16 inch (40 cm) overall length

3/8 inch acceptance
TF030L90 30 Fr (10.0 mm)
TF032L90 32 Fr (10.7 mm)
TF034L90 34 Fr (11.3 mm)
TF036L90 36 Fr (12.0 mm)
TF038L90 38 Fr (12.6 mm)

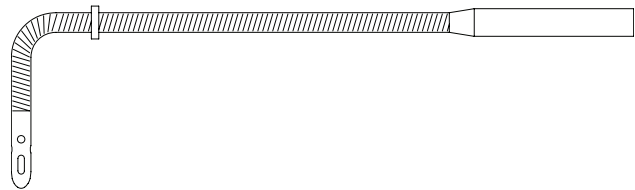

Venous Cannulae

Single Stage Venous Cannula

- One piece wire reinforced cannula
- Proprietary thin-wall design to maximize venous drainage
- Multiple port tip designed to increase drainage
- Thin-Flex venous cannula with proprietary thin-wall technology designed to maximize flow rates

10 units per case

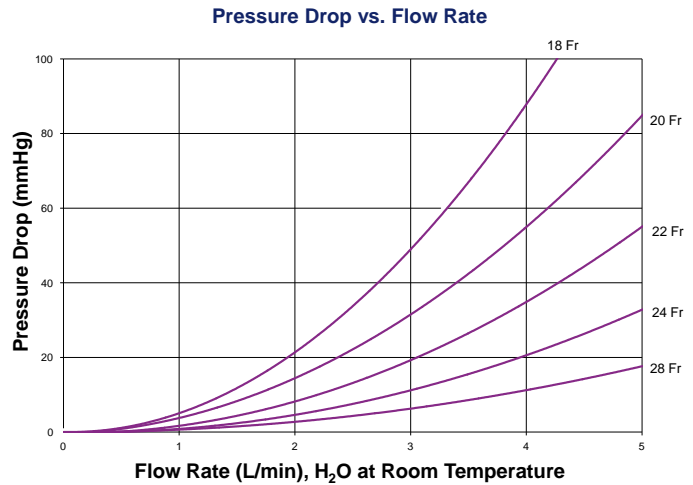

Thin-Flex 90° plastic tip with side holes

14 inch (35 cm) overall length

3/8 inch acceptance

TF018O90 18 Fr (6.0 mm)
TF020O90 20 Fr (6.7 mm)



15 inch (38 cm) overall length

3/8 inch acceptance

TF022O90 22 Fr (7.3 mm)
TF024O90 24 Fr (8.0 mm)
TF028O90 28 Fr (9.3 mm)

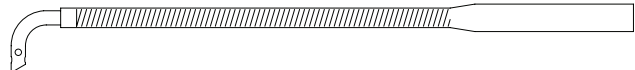

Small Size Dual Stage Venous Cannula

- Thin-Flex venous cannula with proprietary thin-wall technology designed to maximize flow rates
- Patented dual stage drainage baskets designed to provide increased resistance to collapse
- Wire-reinforcement helps reduce kinking and twisting

10 units per case

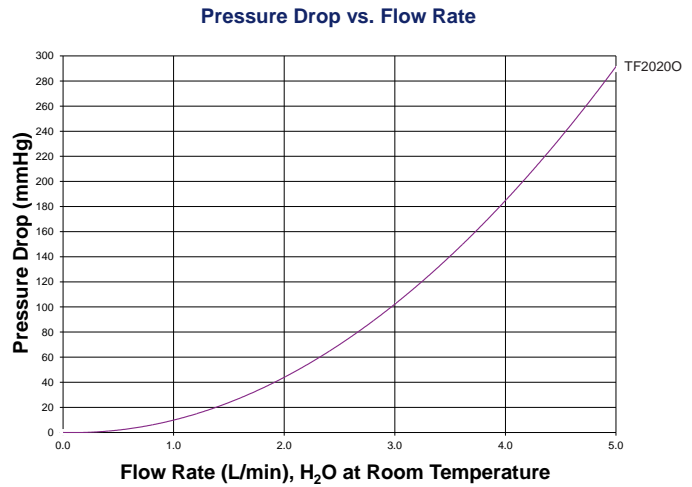

Thin-Flex dual stage venous cannula

14 inch (35 cm) overall length

1/4 inch or 3/8 inch acceptance

TF2020O 20/20 Fr (6.7/6.7 mm)



Venous Cannulae

Small Size Single Stage Venous Cannula

- Thin-Flex venous cannula with proprietary thin-wall technology designed to maximize flow rates

10 units per case

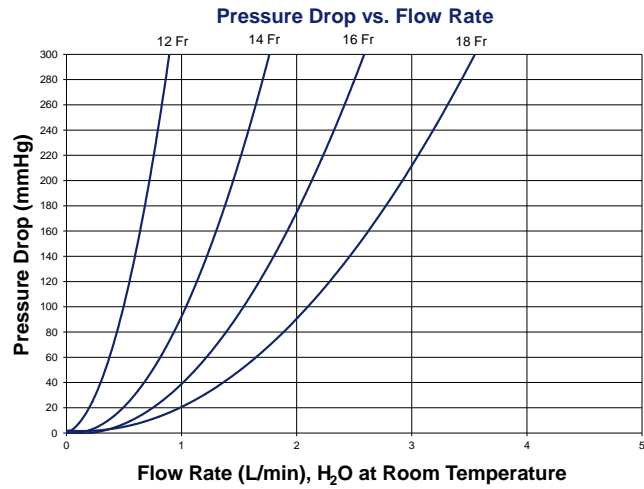

Thin-Flex straight open lighthouse tip

11 inch (28 cm) overall length

1/4 inch acceptance

TF012L	12 Fr (4.0 mm)
TF014L	14 Fr (4.7 mm)
TF016L	16 Fr (5.3 mm)



14 inch (35 cm) overall length

1/4 or 3/8 inch acceptance

TF018L	18 Fr (6.0 mm)
--------	----------------



Venous Cannulae

Small Size Single Stage Venous Cannula

- Thin-Flex venous cannula with proprietary thin-wall technology designed to maximize flow rates

10 units per case

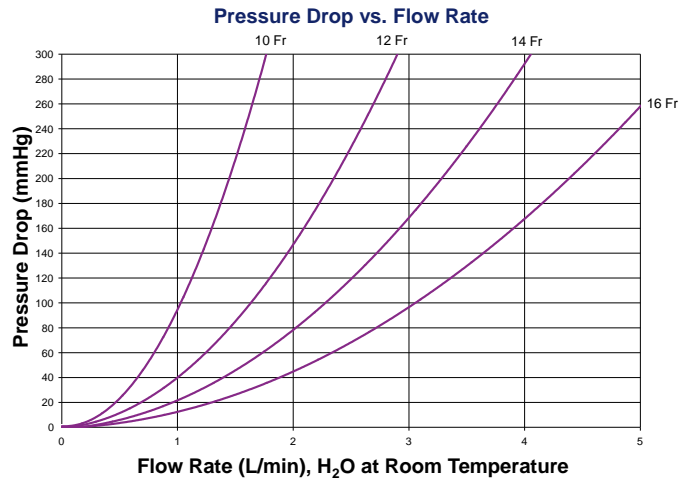

Thin-Flex 90° plastic tip with side holes

11 inch (28 cm) overall length

1/4 inch acceptance

TF010O90

10 Fr (3.3 mm)



13 inch (33 cm) overall length

1/4 inch or 3/8 inch acceptance

TF012O90

12 Fr (4.0 mm)

TF014O90

14 Fr (4.7 mm)

TF016O90

16 Fr (5.3 mm)



Femoral Cannulae

Femoral access cannulae may be used in pediatric populations or adult populations based on flow rate requirements and individual patient anatomy. Please consult labeling to determine pressure drop related to flow rates.

QuickDraw Plus Femoral Venous Cannula

The QuickDraw Plus femoral venous cannula is indicated for draining non-oxygenated blood from the vena cava or right atrium during cardiopulmonary bypass.

- Engineered to facilitate simplified percutaneous insertion
- With proprietary spiraled drainage holes, the cannula is designed for reliable performance with less risk of side occlusion
- Thin-walled technology optimizes flow while maintaining crush and kink resistance

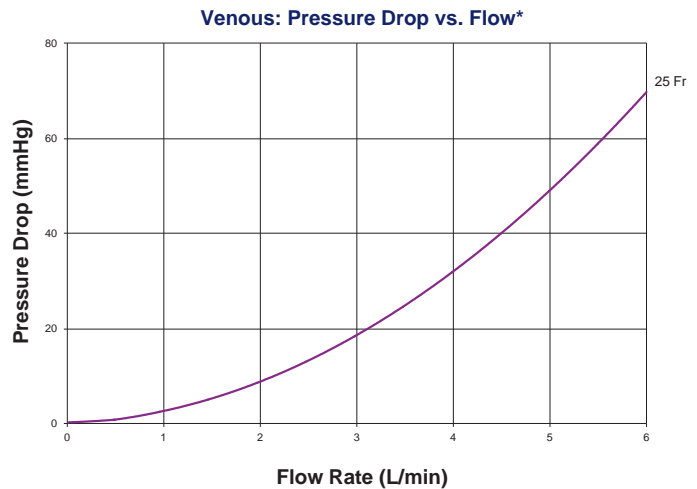

* Mean value derived from In-Vitro testing performed with water at ambient temperature. Due to increased viscosity of blood, actual pressure gradients encountered in a clinical situation may vary from these shown.

1 unit per case

65 cm overall length

QDP25 25 Fr (8.3 mm)

Package contents:

- 25 Fr (8.3 mm) cannula
- Introducer with alignment marker
- 3/8 in (9.5 cm) barbed connector hub



Note: Insertion components are not included.
PIKV5 Percutaneous Insertion Kit is recommended.

Femoral Cannulae

Fem-Flex II Femoral Arterial Cannula

Fem-Flex II femoral arterial cannula is designed with thin-wall technology for enhanced flow and flexibility.

- Tapered tip and smooth dilator to cannula transition facilitates insertion
- Polyurethane body with wire reinforcement helps reduce kinking
- Radiopaque striping for visualization during placement
- Accommodates up to 0.038 inch guidewire

1 unit per case

9.5 inch (24 cm) overall length
6.0 inch (15 cm) effective length

3/8 inch vented connector

FEMII016A	16 Fr (5.3 mm)
FEMII018A	18 Fr (6.0 mm)
FEMII020A	20 Fr (6.7 mm)

3/8 inch non-vented connector

FEMII016AS	16 Fr (5.3 mm)
FEMII018AS	18 Fr (6.0 mm)
FEMII020AS	20 Fr (6.7 mm)

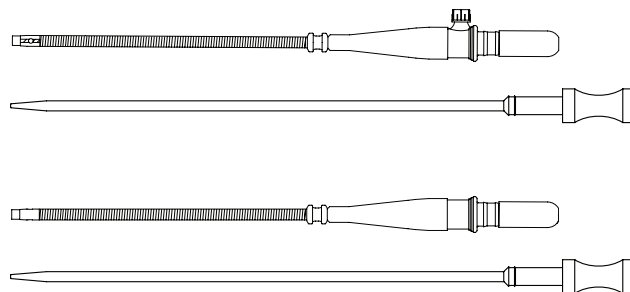
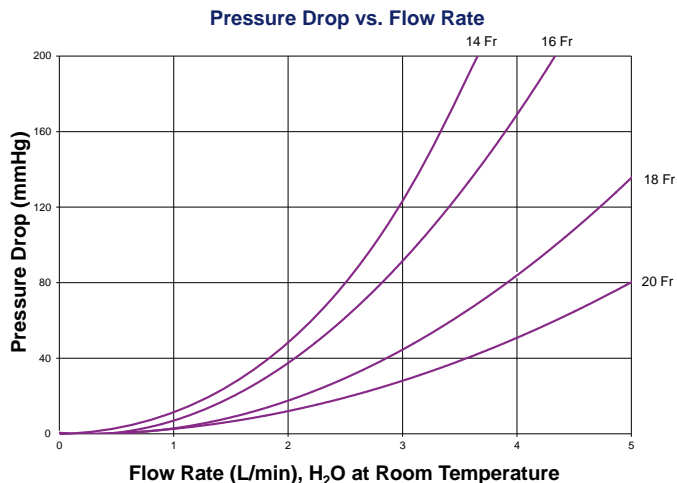

Percutaneous Insertion Kit

The percutaneous insertion kit is designed to facilitate percutaneous insertion of a femoral cannula. The kit includes the following components:

- Number 11 scalpel
- 18 ga. insertion needle
- 5 mL syringe
- Dilator sizes: 8 Fr / 12 Fr / 16 Fr / 20 Fr / 24 Fr
- 0.038 inch guidewire

5 units per case

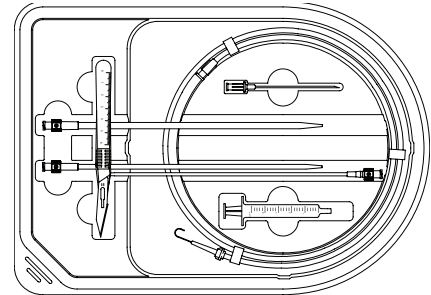

Venous insertion kit

PIKV5

210 cm guidewire

Cardioplegia Catheters

Retrograde coronary sinus cardioplegia catheters may be used in pediatric or adult populations based on the requirements of individual patient anatomy.

Cardioplegia Catheters

Self-Inflating Retrograde Cardioplegia Catheter with Retractable Anti-Retrtraction Technology

The self-inflating retrograde cardioplegia catheter is designed to maximize patient protection by providing global myocardial protection.

- Balloon self-inflates when cardioplegia is being delivered
- Variety of handle and stylet designs that facilitate insertion for a variety of surgical techniques
- Utilizes proprietary Retractableguard anti-retraction technology, which helps the cannula retain its shape after deployment and prevent balloon slippage

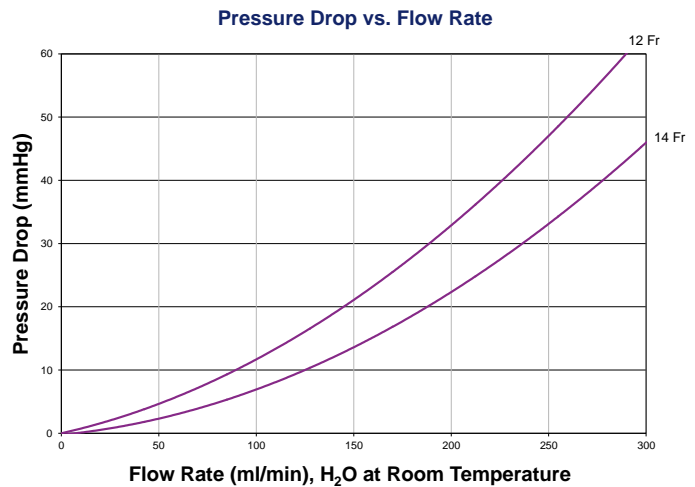

10 units per case

Pre-shaped stylet and handle

10.6 inch (27 cm) overall length

18 mm textured balloon
RC2014S 14 Fr (4.7 mm)

12.5 inch (32 cm) overall length

18 mm textured balloon
RC2012 12 Fr (4.0 mm)
RC2014 14 Fr (4.7 mm)

20 mm textured balloon
RC2014LB 14 Fr (4.7 mm)

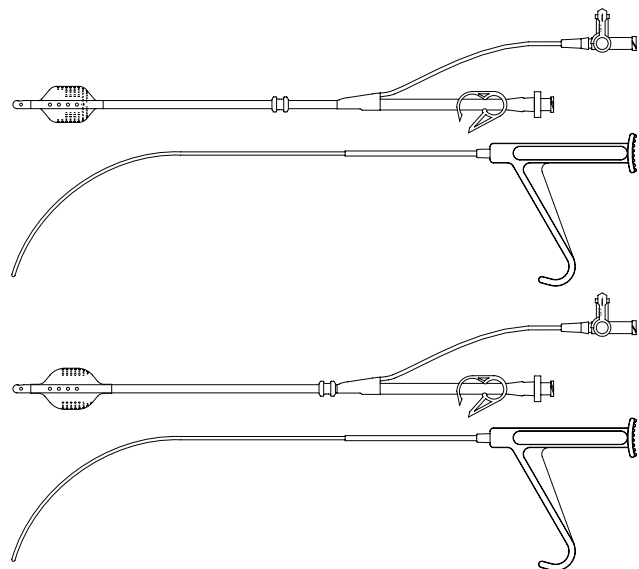

Self-Inflating Retrograde Cardioplegia Catheter with Retractaguard Anti-Retraction Technology (continued)

Guidewire stylet

12.5 inch (32 cm) overall length

- 18 mm textured balloon
- RC2012M 12 Fr (4.0 mm)
- RC2014M 14 Fr (4.7 mm)

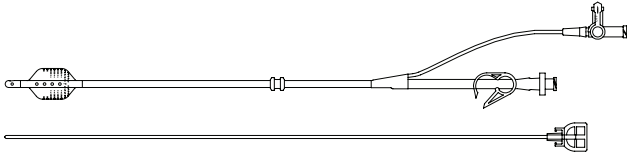

Cardioplegia Catheters

Self-Inflating Retrograde Cardioplegia Catheter

The self-inflating retrograde cardioplegia catheter is designed to maximize patient protection by providing global myocardial protection.

- Balloon self-inflates when cardioplegia is being delivered
- Variety of handle and stylet designs that facilitate insertion for a variety of surgical techniques

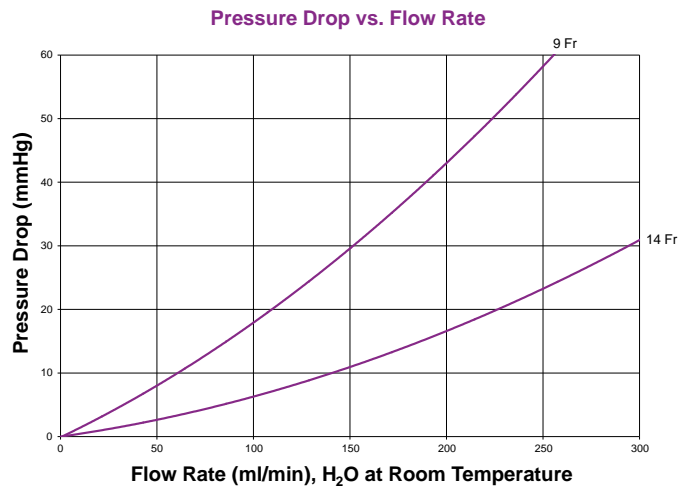

Pre-shaped stylet and handle

5 units per case

8 inch (20 cm) overall length

9 mm smooth balloon

RC09

9 Fr (3.0 mm)

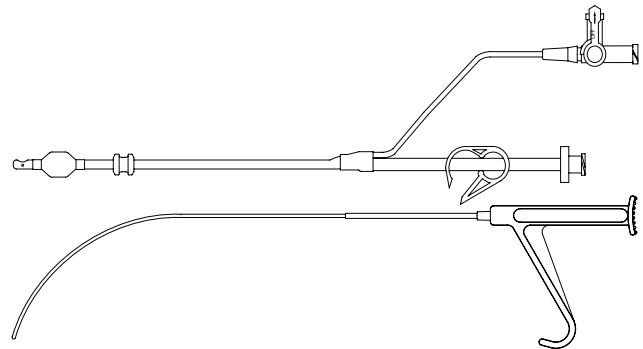

10 units per case

10.6 inch (27 cm) overall length

18 mm smooth balloon

RC014

14 Fr (4.7 mm)

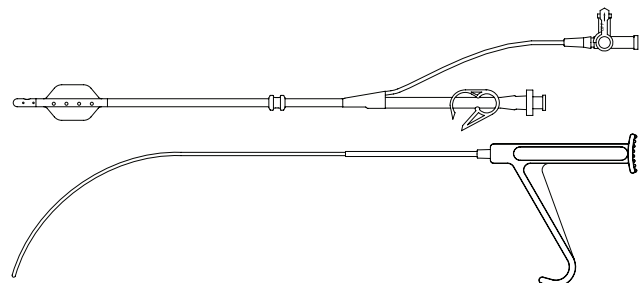

14 mm textured balloon

RC014IT

14 Fr (4.7 mm)

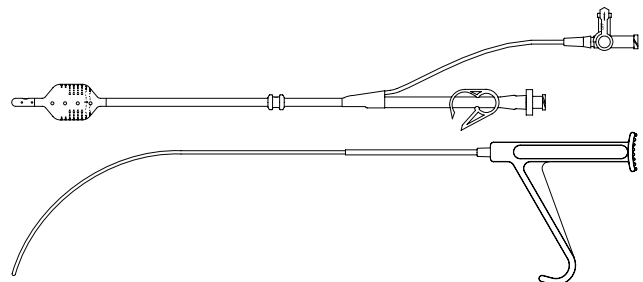

18 mm textured balloon

RC014T

14 Fr (4.7 mm)

Self-Inflating Retrograde Cardioplegia Catheter (continued)

Guidewire stylet

5 units per case

8 inch (20 cm) overall length

9 mm smooth balloon

RC09M

9 Fr (3.0 mm)

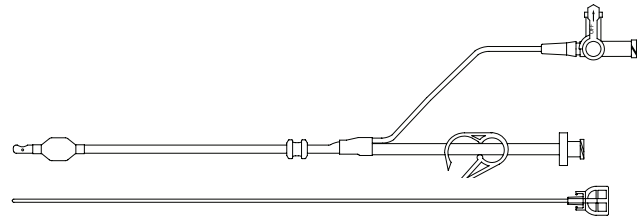

10 units per case

10.6 inch (27 cm) overall length

18 mm smooth balloon

RC014M

14 Fr (4.7 mm)

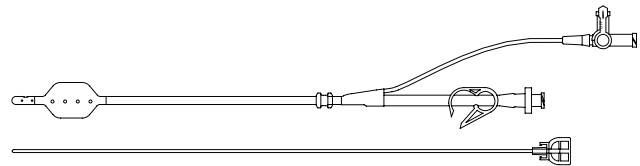

Cardioplegia Catheters

Manually Inflating Retrograde Cardioplegia Catheter

The manually inflating retrograde cardioplegia catheter is designed to maximize patient protection by providing global myocardial protection.

- Manual inflation of the balloon allows surgical control over balloon inflation
- Variety of handle and stylet designs that facilitate insertion for a variety of surgical techniques
- Optional Retractableguard anti-retraction technology to prevent balloon slippage

10 units per case

Pre-shaped stylet and handle

12.5 inch (32 cm) overall length

Textured polyurethane balloon
and retractaguard lumen

RC2014MIBB 14 Fr (4.7 mm)

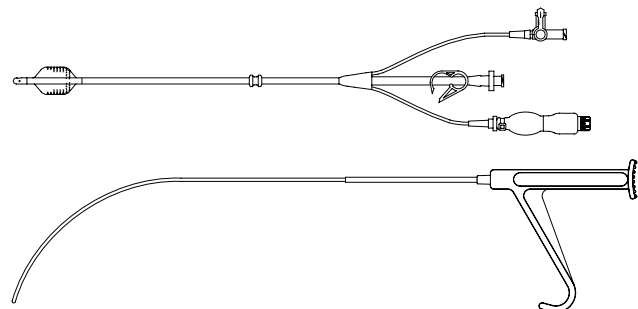
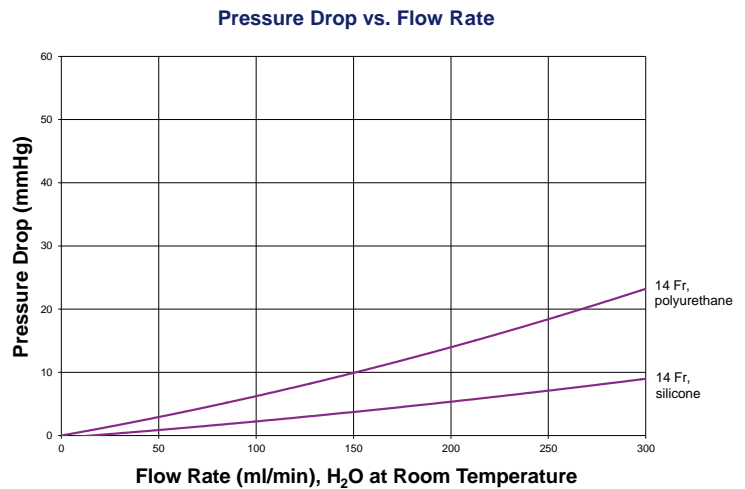

Index

- *Minimally Invasive Devices*
- *Cardiac Cannulae*

Minimally Invasive Devices

Retrograde cardioplegia	Arterial cannulae	Accessory devices
PR9 6	ER21B 8	TRS 11
Aortic occlusion	ER23B 8	TRM 11
ICF100 7	IS19A 8	TRL 11
Femoral venous cannulae	OPTI16 9	KP1 11
QDP25 10	OPTI18 9	4800 12
	OPTI20 9	PIKV5 13
	OPTI22 9	

Cardiac Cannulae

Arterial cannulae	TF026L 26	TR3240OA 25
EZC21A 18	TF026L90 27	TR3651B 25
EZC21TA 18	TF028L 26	TRF2937O 23
EZC24A 18	TF028L90 27	TRF2937OA 23
EZC24TA 18	TF028O90 28	TRF2937O2 21
EZF21A 18	TF030L 26	TRF2937O2A 21
EZF21TA 18	TF030L90 27	TRF3646O 23
EZF24A 18	TF032L 26	TRF3646OA 23
EZF24TA 18	TF032L90 27	TRF3646O2 21
EZS21A 17	TF034L 26	TRF3646O2A 21
EZS21TA 17	TF034L90 27	
EZS24A 17	TF036L 26	Femoral cannulae
EZS24TA 17	TF036L90 27	FEMII016A 34
OPTI16 16	TF038L 26	FEMII016AS 34
OPTI18 16	TF038L90 27	FEMII018A 34
OPTI20 16	TF040L 26	FEMII018AS 34
OPTI22 16	TF2020O 29	FEMII020A 34
	TF292901 24	FEMII020AS 34
Venous cannulae	TF2937O 24	QDP25 33
QDP25 20	TF2937OA 24	PIKV5 35
TF010O90 31	TF2937O120 24	
TF012L 30	TF292902 22	Cardioplegia catheters
TF012O90 31	TF292902A 22	RC09 39
TF014L 30	TF293702 22	RC09M 40
TF014O90 31	TF293702A 22	RC014 39
TF016L 30	TF3343O 24	RC014IT 39
TF016O90 31	TF3343OA 24	RC014M 40
TF018L 26,30	TF3646O 24	RC014T 39
TF018O90 28	TF3646OA 24	RC2012 37
TF020L 26	TF3646O120 24	RC2012M 38
TF020O90 28	TF3646OA120 24	RC2014 37
TF022L 26	TF3646O2 22	RC2014LB 37
TF022O90 28	TR2838L 25	RC2014M 38
TF024L 26	TR3240L 25	RC2014MIBB 41
TF024L90 27	TR3446L 25	RC2014S 37
TF024O90 28	TR3240O 25	



Customer Service Policies

Customer service US only

enableCV
6967 S River Gate Dr Suite 104
Midvale, UT 84047
Customer Service: 1 888 943 2783

For next day delivery, non-emergency, orders must be received by 4:00PM Eastern / 1:00PM Pacific.

enableCV is a partner of the Global Healthcare Exchange (GHX) for Electronic Data Interchange (EDI). You may also place orders by emailing orders@enablecv.com.

For more information about buying enableCV products please speak with a Customer Service Representative.

Terms and conditions

Prices: Subject to change without prior notice. All applicable taxes will be charged. All prices are quoted FOB shipping port. Payment: Net 30 days

Returned goods policy

1. enableCV is committed to providing our customers with quality products and service. Therefore, we will accept for return and full credit and product that:
 - a. Is a result of an error by enableCV
 - b. Does not perform satisfactorily for the purposes and indications described in the labeling
2. Authorization is required for all returns and may be obtained through Customer Service. A Returned Goods Authorization number will be issued, and this number must be referenced on all returned packages. Freight on all returns must be prepaid by the customer except for returns listed in section one.
3. All products must be authorized for return within 30 days from the date of invoice except for returns listed in section one.
4. All returned products will be subject to a 20% handling and restocking fee except for returns listed in section one.
5. The following material is not acceptable for return:
 - a. Sterile items that are returned without the manufacturing seals intact
 - b. Incomplete cases
 - c. Product which has less than 13 months of shelf life
 - d. Product which has been marked or labeled with anything other than the standard enableCV / Edwards labels
6. As part of an ongoing effort to improve the quality of our products, we would like any defective product to be returned for evaluation. Credit or replacement will be issued by enableCV upon receipt of the defective product.

Return instructions for all products

Please contact Customer Service for return instructions.

CAUTION: Federal (United States) law restricts this device to sale by or on the order of a physician.



See instructions for use electronically at eIFU.enableCV.com for full prescribing information, including indications, contraindications, warnings, precautions, and adverse events.

enableCV, the enableCV stylized logo, EndoReturn, EZ Glide, Fem-Flex II, IntraClude, OptiSite, ProPlege, QuickDraw, RetractableGuard, Thin-Flex, and Trim-Flex are trademarks of enableCV, LLC and its affiliates. All other trademarks are the property of their respective owners.

© 2026 enableCV, LLC. All rights reserved. ECV-SM-0050 01



enableCV • enablecv.com
6967 S. River Gate Drive, Suite 104, Midvale, UT 84047